

STANDARD POWER TROWELS

Built for performance, long life and easy operation

- Guaranteed Gear Box for heavy trowelling and rough handling
- Centrifugal Safety Stop switch that shuts the engine down automatically in the event of operational emergencies
- Precision control for blade pitch to ensure precise blade adjustment
- Sturdy tri-tube chrome plated handle engineered to provide greater leverage and ease of control
- Chrome guard ring for easy cleaning
- Lifting hook for easy transport
- Universal blades interchangeable with major trowel brands
- Choice of various Petrol and Diesel engines like Honda, Robin, B&S Lombardini etc.

| Product Code | Model | Engine Type | Engine | Power HP | Path mm | Weight Kgs |
|--------------|---------|-------------|-----------------|----------|---------|------------|
| BTC436SL | 436-90 | Petrol | Honda GX-160 | 5.5 | 900 | 75 |
| BTC436200SL | 436-90 | Petrol | Honda GX-200 | 6.0 | 900 | 75 |
| BTC4362SL | 436-90 | Petrol | Honda GX-270 | 9.0 | 900 | 85 |
| BTC4363SL | 436-90 | Petrol | Honda GX-340 | 11.0 | 900 | 92 |
| BTC436SLLD | 436-90 | Diesel | Lombardini I5LD | 7.5 | 900 | 92 |
| BTC446SL | 446-120 | Petrol | Honda GX-270 | 9.0 | 1200 | 110 |
| BTC4461SL | 446-120 | Petrol | Honda GX-340 | 11.0 | 1200 | 115 |
| BTC4463SL | 446-120 | Petrol | Honda GX-390 | 13.0 | 1200 | 115 |
| BTC446SLLD | 446-120 | Diesel | Lombardini I5LD | 7.5 | 1200 | 110 |

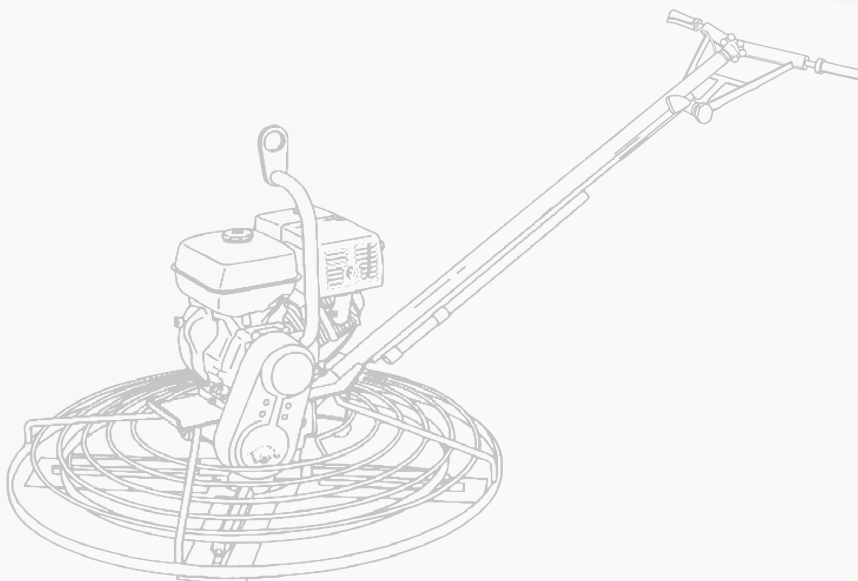

| Consumables Product Codes | | |
|---------------------------|--------|--------|
| Model | Blades | Pans |
| 436-90 | 000203 | 000226 |
| | 000191 | |
| | 000171 | |
| 446-120 | 000204 | 000227 |
| | 000192 | |
| | 000173 | |

